

JPE 4-4-5

A Flyback Transformer linked Soft Switching PWM DC-DC Power Converter using Trapped Energy Recovery Passive Quasi-Resonant Snubbers with an Auxiliary Three-Winding Transformer

Tarek Ahmed[†], Srawouth Chandhaket^{*}, Mutsuo Nakaoka^{*}, Song Hwa Jung^{**} and Hyun-Woo Lee^{**}

^{*}The Graduate School of Science and Engineering, Yamaguchi University, Yamaguchi, Japan

^{**}The Electric Energy Saving Research Center, Kyungnam University, Masan, Korea

ABSTRACT

In this paper, a two-switch high frequency flyback transformer linked zero voltage soft switching PWM DC-DC power converter implemented for distributed DC- feeding power conditioning supplies is proposed and discussed. This switch mode power converter circuit is mainly based on two main active power semiconductor switches and a main flyback high frequency transformer linked DC-DC converter in which, two passive lossless quasi-resonant snubbers with pulse current regeneration loops for energy recovery to the DC supply voltages composed of a three winding auxiliary high frequency pulse transformer, auxiliary capacitors and auxiliary diodes for inductive energy recovery discharge blocking due to snubber capacitors are introduced to achieve zero voltage soft switching from light to full load conditions. It is clarified that the passive resonant snubber-assisted soft switching PWM DC-DC power converter has some advantages such as simple circuit configuration, low cost, simple control scheme, high efficiency and lowered noises due to the soft switching commutation. Its operating principle is also described using each mode equivalent circuit. To determine the optimum resonant snubber circuit parameters, some practical design considerations are discussed and evaluated in this paper. Moreover, through experimentation the practical effectiveness of the proposed soft switching PWM DC-DC power converter using IGBTs is evaluated and compared with a hard switching PWM DC-DC power converter.

Keywords: Passive resonant snubbers, auxiliary pulse current regeneration, DC-DC converter, pulse transformer assisted-energy regeneration, two switch flyback transformer link, soft switching PWM.

1. Introduction

In recent years, high performance and high power

Manuscript received May 28, 2004; revised August 31, 2004

[†]Corresponding Author: tarek@pe-news1.eee.yamaguchi-u.ac.jp

Tel: +81-836-85-9472, Fax: +81-836-85-9401, Yamaguchi Univ.

^{*}The Graduate School of Science and Eng., Yamaguchi Univ.

^{**}The Electric Energy Saving Research Center, Kyungnam Univ.

density switching mode power supplies with high frequency transformers have been developed for high power applications. These include electric vehicles and automobiles, new energy generation and storage interfaced utilization power sources, AC - UPS and DC - UPS for telecommunication and information equipment and industrial power conditioning and processing plants. In particular, for auxiliary switching mode high power DC

supply applications in rolling stock transportation, high frequency transformer linked DC-DC power converters have already been introduced. Since comparatively high DC voltages of 1500V, 750V and 600V are actually provided from the main DC feeding power supply of the rolling stock transportation equipment^[1], active power semiconductor switching devices and modules with high maximum DC voltage ratings have to be utilized for the switch mode DC-DC power converters with high-frequency transformer stages. This is due to spike voltage surges and peaky ringing current surges. However, their switching responses inherently become much slower as the maximum voltage ratings of the power devices increase, making high frequency switching, high performance and high power density “downsizing” of the electrically isolated DC-DC power converter difficult to implement practically. To solve these problems, a cascade configuration DC-DC power converter with a high frequency transformer link is employed^[2] as illustrated in Fig. 1. In this converter, due to the interleaved configuration of the output filter side, active power semiconductor devices with lower voltage ratings and faster switching responses can be utilized effectively.

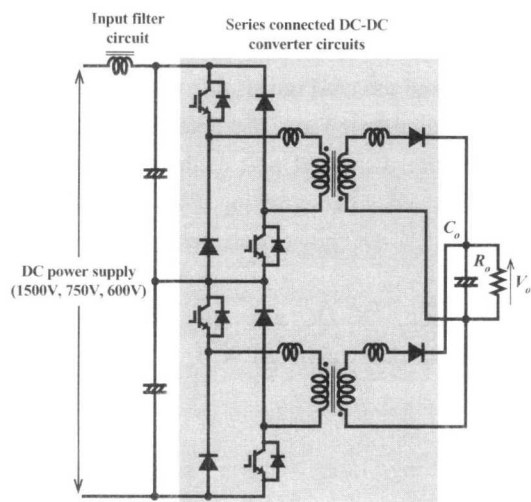

Fig. 1 Interleaved cascade DC-DC power converters with flyback transformers for high input DC voltage supply

In this context, a variety of high frequency hard switching PWM DC-DC power converter topologies have been proposed to increase converter power density and power conversion efficiency. However, in traditional hard

switching PWM DC-DC power converters, high frequency switching leads to an increase in the power losses of high power semiconductor devices and the packaging power modules they use. Additionally, it increases dv/dt and di/dt related surges and electromagnetic noise levels.

In order to overcome these practical problems, a simple two-switch flyback transformer passive snubber-assisted soft switching PWM DC-DC power converter with a pulse current regeneration snubber circuit for energy recovery to the DC input side is proposed by the authors. The circuit uses a minimum number of passive circuit components in the auxiliary resonant snubbers to achieve zero voltage soft commutation. Due to its simple configuration the proposed soft switching PWM DC-DC power converter with high-frequency flyback transformer link is able to operate using single PWM signal sequences, thus establishing a low-cost circuit arrangement and simple output voltage feedback control scheme for high power applications. These applications include rolling stock transportations, new energy interfaced distributed power supplies and power conditioners for electric vehicles and telecommunication DC feeding plants. The operating principle of this DC-DC power converter with auxiliary pulse current regenerative passive resonant snubbers, its steady state operating characteristics, and some parameters for practical circuit parameters design are described and analyzed theoretically. Moreover, the circuit's operating performance in steady state is also compared to a hard switching PWM DC-DC power converter with a high frequency flyback transformer. To verify the practical effectiveness of the newly proposed soft switching PWM DC-DC power converter with pulse transformer linked passive resonant snubbers, a 1.3kW, 25kHz breadboard setup of the DC-DC converter using IGBTs is implemented and evaluated herein.

2. Circuit Configuration and Operating Principles

2.1 Circuit Description

In Fig. 2, the two switch flyback transformer high-frequency hard switching PWM DC-DC power converter circuit is depicted. In Fig. 3, the proposed circuit topology of the high-frequency flyback transformer soft

switching PWM DC-DC power converter using passive resonant snubbers with an auxiliary high-frequency energy recovery pulse transformer is illustrated. The auxiliary resonant snubbers of this proposed PWM DC-DC power converter can also operate as a forward type one transformer [3-4]. However, due to the leakage inductance specified by the high-frequency pulse transformer some additional diodes and inductors have to be connected to the auxiliary output side, increasing cost and physical volumetric size.

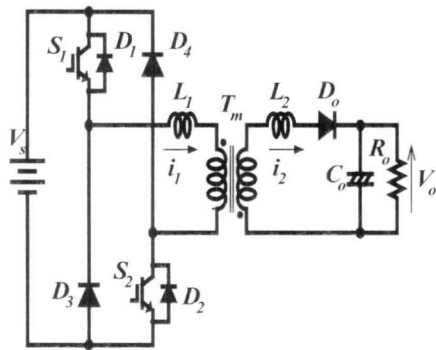

Fig. 2 Conventional Two-switch hard switching flyback type PWM DC-DC converter circuit

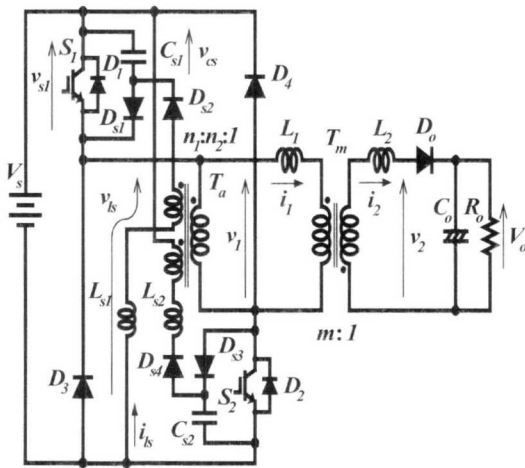

Fig. 3 Proposed high frequency flyback type soft switching PWM DC-DC power converter circuit with two switches and three-winding pulse transformer linked passive resonant snubbers

The primary side of the main high frequency transformer of the soft switching PWM DC-DC power converter is composed of two active power switches $Q_1(S_1,$

$D_1)$ and $Q_2(S_2, D_2)$ and two voltage clamping diodes (D_3, D_4) which suppress the voltages across $Q_1(S_1)$ and $Q_2(S_2)$ to the input DC supply voltage V_s . The passive snubber circuit with pulse current regeneration for the auxiliary energy recovery pulse transformer is composed of auxiliary snubber diodes (D_{s1}, D_{s3}), auxiliary snubber capacitors (C_{s1}, C_{s2}), auxiliary diodes (D_{s2}, D_{s4}) and an auxiliary three winding high frequency transformer T_a where resonant leakage inductors L_{s1} and L_{s2} are included in this converter circuit. The high frequency flyback transformer T_m is represented by its turns ratio m and leakage inductors L_1 and L_2 .

2.2 Operating Principles and Analysis

In Fig. 4, the typical voltage and current operating waveforms of the proposed DC-DC power converter circuit topology with a high-frequency flyback isolated transformer are illustrated and each equivalent circuit stage operation is represented in Fig. 5. The following assumptions describe its operating principles under steady-state periodic conditions.

(i) The active and passive power switches and circuit components are ideal.

(ii) Primary and secondary windings of the auxiliary forward pulse transformer T_a are identical. Its turns ratio in relation to the tertiary winding and their resonant leakage inductances are respectively represented by $n_1 = n_2 = n$ and $L_{s1} = L_{s2} = L_s$, respectively

(iii) Surge absorbing capacitors C_{s1} and C_{s2} are identical; $C_{s1} = C_{s2} = C_s$.

The steady-state periodic operation of this soft switching DC-DC power converter circuit is described as follows:

(a) Mode 0 ($t_0 \sim t_1$): At time t_0 , according to the duty factor D ($D = t_{on}/T$; see Fig.4) of the soft switching PWM DC-DC power converter treated here, $Q_1(S_1)$ and $Q_2(S_2)$ are turned on simultaneously under a condition of zero current switching, since $(L_1+m^2L_2)$ and the leakage inductance of the auxiliary three winding high frequency forward type pulse transformer exist in their current path. A voltage nV_s is reflected to the primary and secondary windings of auxiliary pulse transformer T_a . As a result, quasi-resonance starts based on L_s and C_s . For energy recovery, the pulse current i_{is} flows through the current

regeneration loop composed of L_{s1} (L_{s2}), D_{s2} (D_{s4}), C_{s1} (C_{s2}) and V_s and the resonant snubbing capacitor voltage v_{cs} is discharged toward zero. The circuit state equations for this operation mode are expressed below:

$$V_s = -L_s \frac{di_{ls}}{dt} + v_{cs} + nV_s, \quad \frac{dv_{cs}}{dt} = -\frac{1}{C_s} i_{ls} \quad (1)$$

Assuming that $v_{cs} = V_{s0}$ and $i_{ls} = 0$ at time t_0 , the state equations for the resonant snubber capacitor voltage and pulse regeneration current are represented by:

$$i_{ls} = \frac{V_{s0} - (1-n)V_s}{Z_s} \sin \omega_s t \quad (2)$$

$$v_{cs} = \{ V_{s0} - (1-n)V_s \} \cos \omega_s t + (1-n)V_s$$

where $Z_s = \sqrt{L_s/C_s}$ is the resonant characteristic impedance and $\omega_s = 1/\sqrt{L_s C_s}$ is the resonant angular frequency.

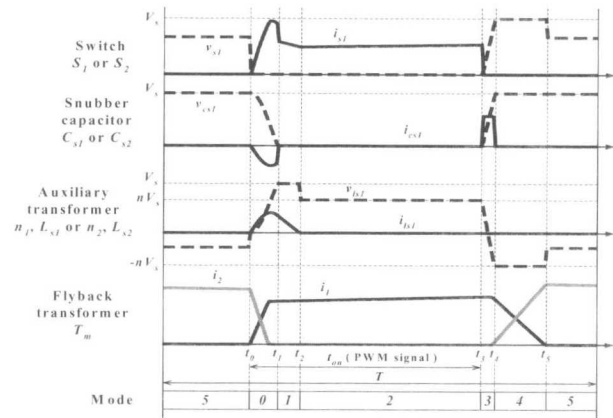

Fig. 4 Theoretical operating waveforms of the proposed PWM DC-DC converter

From (2), it is noted that the resonant snubbing capacitor C_s is fully discharged at $\omega_s t = \pi$ and the resonant snubbing capacitor voltage v_{cs} becomes less than zero at this time. When $v_{cs} < 0$, the condition $1 - V_{s0}/2V_s < n$ can be obtained analytically.

On the other hand, the current flowing through the active power semiconductor switch $Q_1(S_1)$ and $Q_2(S_2)$ is derived from the flyback transformer secondary side current i_2 and

the regeneration current i_{ls} . Therefore, the maximum di/dt of each active power semiconductor switch at the turn on transition can be represented by:

$$\frac{di}{dt} = 2 \frac{nV_{s0} - n(1-n)V_s}{L_s} + \frac{V_s + mV_o}{L_1 + m^2 L_2} \quad (3)$$

(b) Mode 1 ($t_1 \sim t_2$): the resonant capacitance C_s is fully discharged, when D_{s1} and D_{s3} turn on. In this mode, the pulse regeneration current for energy recovery to the DC supply source V_s is not allowed to flow continuously. As a result, the additional condition of $n < 1$ should be considered, and the equation to determine the turns ratio of the auxiliary high frequency transformer T_a with a tertiary winding can be rearranged as:

$$1 - V_{s0}/2V_s < n < 1 \quad (4)$$

where V_{s0} is the initial voltage across the resonant snubber capacitor C_s at t_0 .

(c) Mode 2 ($t_2 \sim t_3$): In this mode, the regeneration current i_{ls} reaches zero and magnetic energy is stored into the primary winding side of the flyback high frequency transformer T_m .

(d) Mode 3 ($t_3 \sim t_4$): According to the duty factor D ($D = t_{on}/T$), $Q_1(S_1)$ and $Q_2(S_2)$ turn off simultaneously when using zero voltage soft switching. The resonant snubber capacitor C_s starts to charge and voltage across the active power semiconductor switches increases linearly with a certain slope. The voltage across C_s is charged to V_{s0} as specified above.

(e) Mode 4 ($t_4 \sim t_5$): both D_{s1} and D_{s3} turn off and energy stored in $(L_1 + m^2 L_2)$ and the leakage inductance of the auxiliary three winding high frequency pulse transformer T_a is released to the input supply voltage V_s through clamping diodes D_3 and D_4 . The secondary winding current i_2 starts to flow through the secondary side of the flyback transformer T_m .

(f) Mode 5 ($t_5 \sim t_0$): Energy stored in the primary side of the flyback transformer T_m is discharged through its secondary side and the secondary winding current i_2 flows through L_2 , the output blocking diode D_o and output filter capacitor C_o . Additionally, DC-output power is delivered to the load R_o under a condition of regulated output DC voltage V_o .

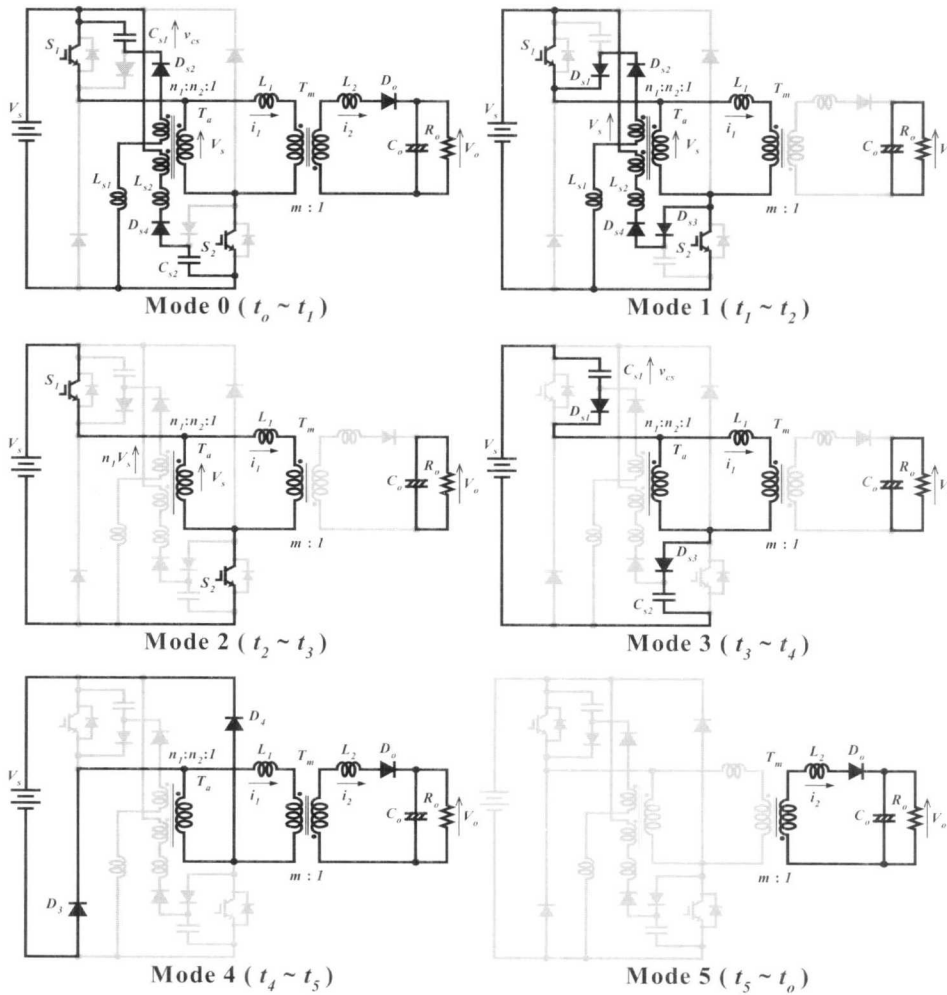

Fig. 5 Equivalent circuits for each commutation stage

3. Design Considerations of Passive Resonant Snubbers

Considering the turns ratio of the auxiliary high frequency transformer T_a as $n_1 = n_2 = n$ (the turns ratio of the primary and secondary windings in relation to the tertiary winding); setting n according to (4) is indispensable for achieving a soft switching commutation mode transition which is independent of the DC output power.

The circuit parameters of passive resonant snubbers with auxiliary pulse transformer T_a are designed for this DC-DC power converter where the DC source voltage $V_s = 300V$. The output DC voltage V_o and switching frequency f are 100V and 25kHz, respectively. In addition, the following practical conditions must be met in order to

select the optimum circuit parameters:

(a) The full discharging interval t_s of the resonant snubber capacitors (in this case, C_{s1} and C_{s2}) should be designed to be 3% - 5% of one switching period $T (= 1/f)$. As a result, t_s is given by,

$$t_s = \pi \sqrt{L_s C_s} \quad , \quad 0.03 < t_s \cdot f < 0.05 \quad (5)$$

(b) The maximum dv/dt value during the turn off period of the active power semiconductor switch Q_1 or Q_2 should be specified as 1000V/ μ s.

(c) The maximum di/dt value at the turn on transition of the active power semiconductor switch Q_1 or Q_2 should be specified as 40A/ μ s. Each circuit parameter, which meets the three conditions (a) - (c) mentioned above, is designed

for the following methods:

(i) $C_{s1} = C_{s2} = C_s$ is set to $0.015\mu\text{F}$ and from (4), n is set to 0.67.

(ii) From (5), $L_{s1} = L_{s2} = L_s$ is determined. As a result, $9.7\mu\text{H} < L_s < 27\mu\text{H}$.

(iii) To satisfy condition (b), the allowable maximum power semiconductor switch current i_{smax} assumes that $Q_1(S_1)$ or $Q_2(S_2)$ is specified to 15A at time of turn off, since $dv/dt = i_s/C_s$ and to meet condition (c), the maximum di/dt capacity is determined by (3).

4. Experimental Evaluations and Discussions

The operating principle and steady state characteristics of the proposed soft switching PWM DC-DC power converter with a high-frequency flyback transformer link are verified by 1.3kW ($V_o = 100\text{V}$) 25kHz breadboard setup. Using IGBTs as the main active power switches, Q_1 and Q_2 are implemented and evaluated in the following experiment. The design specifications and circuit parameters of this DC-DC power converter as shown in Fig.3 are as follows:

$$V_s = 300\text{V}, \quad C_{s1} = C_{s2} = C_s = 0.015\mu\text{F}$$

$$S_1/D_3, S_2/D_4: \text{CM75DY-12H}, V_{ces} = 600\text{V}, I_c = 75\text{A}$$

$$D_{s1}, D_{s2}, D_{s3}, D_{s4}: 30\text{JL2C41}, V_{RRM} = 600\text{V}, I_F = 30\text{A}$$

$$T_m: L_l = 19.5\mu\text{H} \text{ (magnetizing inductance } L_m = 2.63\text{mH)},$$

The measured voltage and current waveforms of the active power semiconductor switches Q_1 and Q_2 are illustrated in Fig. 6 and Fig. 7, respectively, where the DC supply voltage $V_s = 300\text{V}$, the DC output voltage $V_o = 100\text{V}$, and the DC output power $P_{out} = 1\text{kW}$. From the results illustrated in Fig.6, one can verify that both active power semiconductor switches can turn off under the zero voltage soft commutation since the resonant snubber capacitors are fully discharged and can turn on when there is no current due to the primary side and secondary side leakage inductances of the high-frequency flyback transformer and auxiliary three winding high frequency pulse transformer. The voltage across the resonant snubber capacitor C_{s1} and the regeneration current i_{s1} for energy

pulse recovery are illustrated in Fig. 8. Observing Fig. 8, one can see that the voltage across the resonant snubber capacitor v_{cs1} is discharged toward zero before $Q_1(S_1)$ turns off and the regeneration current only flows during the turn-on switching mode transition interval. It can also be observed that for heavy load conditions, the maximum voltage across C_{s1} is higher than the input voltage V_s since some parasitic wiring inductances exist through the DC busline.

In Fig. 9 and Fig. 10, the voltage and current waveforms of the active power semiconductor switches Q_1 and Q_2 are also shown under light load conditions of $V_s = 300\text{V}$, $V_o = 100\text{V}$ and $P_{out} = 150\text{W}$. From these experimental results, one can see that zero voltage soft switching is achievable under light load conditions.

In Fig. 11, the total measured actual efficiency in relation to the output power P_{out} is represented for the conventional two-switch flyback hard switching PWM DC-DC power converter with a high-frequency flyback transformer link and the proposed two-switch soft switching PWM DC-DC power converter using passive lossless resonant snubbers with an auxiliary energy recovery pulse transformer. From these observed results, one can confirm that the maximum actual efficiency obtained from the two switch flyback transformer type zero voltage soft switching PWM DC-DC power converter is 93.3% and for output power higher than 550W, the converter efficiency increases approximately 1.3% to 1.5% as compared with the conventional two switch flyback hard switching PWM DC-DC power converter(see Fig.1).+

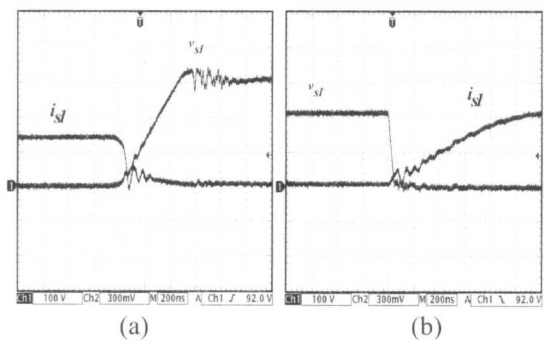

Fig. 6 Voltage and current waveforms of active power switches S_1 under $P_{out}=1\text{kW}$. (a) Turn off, (b) Turn on. (v_{s1} : 100V/div; i_{s1} : 10A/div; time: 0.2 μs /div)

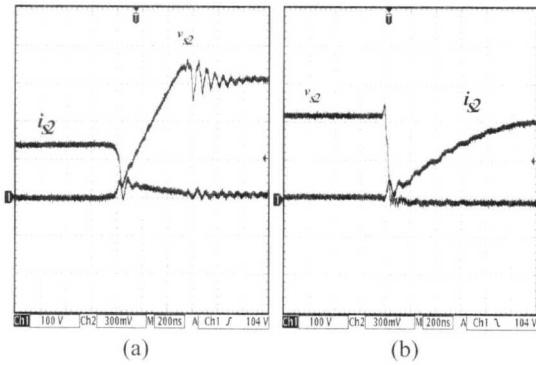

Fig. 7 Voltage and current waveforms of active power switches S_2 under $P_{out}=1kW$. (a) Turn off, (b) Turn on. (v_{s2} : 100V/div; i_{s2} : 10A/div; time: 0.2µs/div)

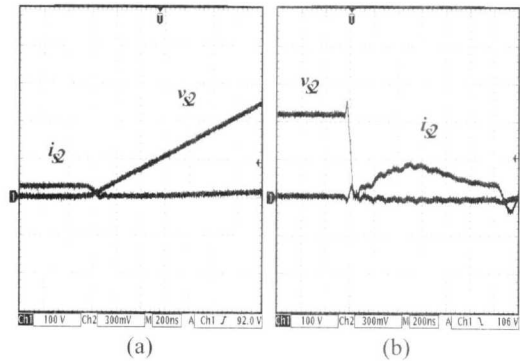

Fig. 10 Voltage and current waveforms of active power switches S_2 under $P_{out}=150W$. (a) Turn off, (b) Turn on. (v_{s2} : 100V/div; i_{s2} : 10A/div; time: 0.2µs/div)
 T_a : $L_{s1} = L_{s2} = L_s = 16\mu H$, $n_1 = n_2 = n = 0.67$

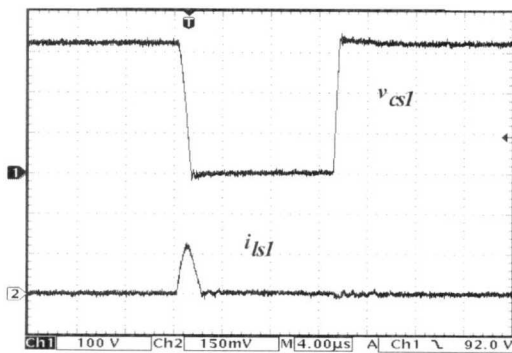

Fig. 8 Voltage across snubber capacitor C_{s1} and regeneration current i_{ls1} (v_{cs1} : 100V/div; i_{ls1} : 5A/div; time: 10µs/div) $L_2 = 11.8\mu H$, $m = 1.285$

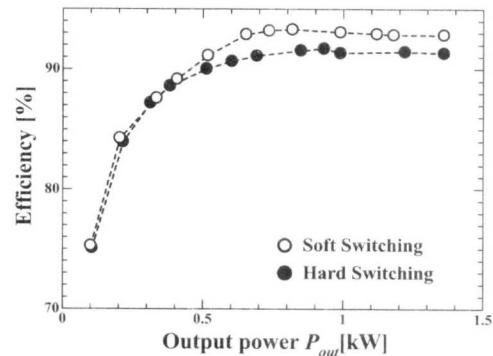

Fig. 11 Measured actual efficiency vs. output power under conditions of $V_s=300V$ and $V_o=100V$

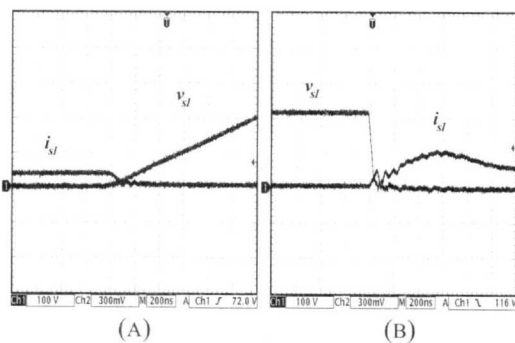

Fig. 9 Voltage and current waveforms of active power switches S_1 under $P_{out}=150W$. (a) Turn off, (b) Turn on. (v_{s1} : 100V/div; i_{s1} : 10A/div; time: 0.2µs/div)

5. Conclusions

A simple two-switch high frequency flyback transformer zero voltage soft switching PWM DC-DC

power converter using IGBTs and incorporating passive resonant snubber circuits with an auxiliary pulse current transformer has been presented in this paper.

We proved by theoretical analysis and experimental evaluations that the proposed soft switching PWM DC-DC power converter circuit could efficiently achieve high performance compared to the conventional two switch flyback hard switching PWM DC-DC power converter circuit. We illustrated its operating principles, performed a steady-state analysis, and discussed a practical way to set the circuit parameters of the lossless passive resonant snubber with a pulse current regeneration loop for energy recovery by means of the resonant snubber including pulse transformer with three-windings. From experimental results, it could be ascertained that the actual efficiency of the DC-DC power converter treated here increases when the two passive lossless resonant snubber circuit using an

auxiliary three winding high frequency pulse transformer is implemented. Finally, the following features of the proposed converter circuit could be verified in future research.

(i) A simple control scheme could be implemented by a single PWM signal generator since two active power semiconductor switches operate simultaneously.

(ii) Passive resonant snubbers with energy recovery are implemented to achieve high efficiency.

(iii) Stable pulse transformer soft switching could be performed under both light and full load conditions.

(iv) The proposed two-switch flyback soft switching PWM DC-DC power converter with high-frequency transformer link is more suitable for high power applications. The interleaving circuit configuration on the basis of the two-switch flyback soft switching DC-DC power converter with pulse transformer linked passive resonant snubber circuit for tapped energy recovery loops should be evaluated from a practical point of view. In addition to this, the two-switch forward transformer soft switching DC-DC power converter with the three winding pulse transformer linked passive resonant snubber circuit for trapped energy recovery loops to the DC supply source side should be studied as compared with the passive resonant snubber assisted soft switching flyback converter topology treated here.

References

- [1] S. Hase, et al. "Control Methods and Characteristics of Power Converter with Large Capacity for Electric Railway System" *Proceeding of PCC-Osaka*, Vol. 3, pp. 1039-1044, April, 2002.
- [2] Y. Konishi, Y. Fujiwara, K. Okamoto, T. Sugimoto "Transistorized Power Supply for Rolling Stock" *Proceedings of IPEC-Tokyo*, pp. 1321-1332, March 1983.
- [3] T. Morimoto, K. Saitou, S. Shirakawa, M. Nakaoka "Transformer Parasitic Reactive Components - Assisted Soft - Switching PWM Inverter Type DC - DC Converter with ZCS Power Switches" *Proceedings of IEEE-PESC*, Vol. 1, pp. 167-172, June 2000.
- [4] S. Hamada, M. Nakaoka "A Novel Zero - Voltage and Zero - Current Switching PWM DC-DC Converter with Reduced Conduction Losses" *IEEE Trans. on Power Electronics*, Vol. 17, No. 3, pp. 413-419, May 2002.
- [5] D. V. Ghodke, K. Muralikrishnan "1.5 kW Two - Switch Forward ZCVS Converter Using Primary Side Clamping" *Proceedings of IEEE-PESC*, Vol. 2, pp. 893-898, June 2002.
- [6] M. T. Aydemir, A. Bendre, G. Venkataramanan "A Critical Evaluation of High Power Hard and Soft Switched Isolated DC-DC Converters" *Proceedings of IEEE-IAS Annual Meeting*, Vol. 2, pp. 1338-1345, October 2002.
- [7] J. P. Lavieville, P. Baudesson, L. Gilbert, J. M. Bodson "Industrial 20kHz/150kVA Insulated Soft Switching DC-DC Converter with No Auxiliary Circuit" *EPE Conference CD-ROM*, August 2001



Tarek Ahmed received his M.Sc. degree in electrical engineering from the Electrical Engineering Department, Faculty of Engineering, Assiut University, Assiut, Egypt in 1998. He is currently working toward the Ph.D. degree in the Power Electronic System and Control

Engineering Laboratory, the Division of Electrical and Electronic Systems Engineering, the Graduate School of Science and Engineering, Yamaguchi University, Yamaguchi, Japan. He is an Assistant Lecturer in the Electrical Engineering Department, Faculty of Engineering, Assiut University. His research interests are in the new applications of advanced high frequency resonant circuits and systems with the renewable energy related soft switching PWM rectifier and sinewave PWM inverter power conditioner. Mr. Ahmed is a student-member of the Institute of Electrical and Electronics Engineers of USA (IEEE-USA), the Institute of Electrical Engineering and Installation of Engineers (IEIE-Japan), the Institute of Electrical Engineers (IEE-Japan) and Japan Institute of Power Electronics (JIPE). He was the recipient of prize paper awards from the Institute of Electrical Engineers of Japan (IEE-J) in 2003 and in 2004.



Srawouth Chandhaket was born in Surin, Thailand. He received his B. Eng. degree in Electronics from Kobe University, Hyogo, Japan in 1995 and also his M. S. degree in Electrical Engineering from Virginia Tech. in 1998. He is currently a Ph. D. candidate

in the Graduate School of Engineering and Science, Yamaguchi University, Yamaguchi, Japan since 2001. His research interests include the soft-switching technology in power electronics and power systems, the stability of power system network and the applications of soft computing in power electronics and power systems. He is a student member of IEEE, the Institute of Electrical Engineers of Japan and the

Japan Solar Energy Society.



Mutsuo Nakaoka received his Dr.-Eng. degree in Electrical Engineering from Osaka University, Osaka, Japan in 1981. He joined the Electrical and Electronics Engineering Department of Kobe University, Kobe, Japan in 1981 and served as a professor of the Department of Electrical and Electronics Engineering at the Graduate School of Engineering, Kobe University, Kobe, Japan until 1995. He is currently working as a professor in the Electrical and Electronics Engineering Department at the Graduate School of Science and Engineering, Yamaguchi University, Yamaguchi, Japan. His research interests include application developments of power electronics circuits and systems. He has received more than ten awards such as the 2001 premium prize paper award from IEE-UK, the 2001 and 2003 Best Paper Awards from IEEE-IECON, the 2000 third paper award from IEEE-PEDS, the 2003 James Melcher Prize Paper award from IEEE-IAS. He is now a chairman of the IEEE Industrial Electronics Society Japan Chapter. Dr. Nakaoka is a member of the Institute of Electrical Engineering Engineers of Japan, the Institute of Electronics, Information and Communication Engineers of Japan, the Institute of Illumination Engineering of Japan, the European Power Electronics Association, the Japan Institute of Power Electronics, the Japan Society of Solar Energy, the Korean Institute of Power Electronics, IEE-Korea and IEEE.



Song Hwa Jung received the B.S. in Electrical engineering from Pukyong University, Pusan, Korea in 1990 and the M.S. degrees in electrical engineering from Kyungnam University, Masan, Korea in 1995, where he is currently the Ph.D. degree in electrical engineering from Kyungnam University, Masan, in 2003. He is currently doing research in Division of electrical energy saving research center(EESRC), Kyungnam University, Korea. His research interest is in the areas of photovoltaic power generation system, power electronics, soft-switching technology. He is a member of the KIEE, KIPE, KIIEE.



Hyun-Woo Lee received the B.E. degrees in electrical engineering from Dong-A University, Pusan, Korea, in 1979 and received the M.S. degrees in electrical engineering from Yuing-Nam University, Kyungbook, Korea, in 1984 and the Ph.D.

degrees in electrical engineering from Dong-A University, Pusan, Korea, in 1992. Since 1985 he has been with the Division of Electrical Electronics Engineering, Kyungnam University, Masan, Korea, where he is a Professor. He is interested in the area of Power electronics and new power generation system. He is a member of the KIEE, IEEE.